

A-A

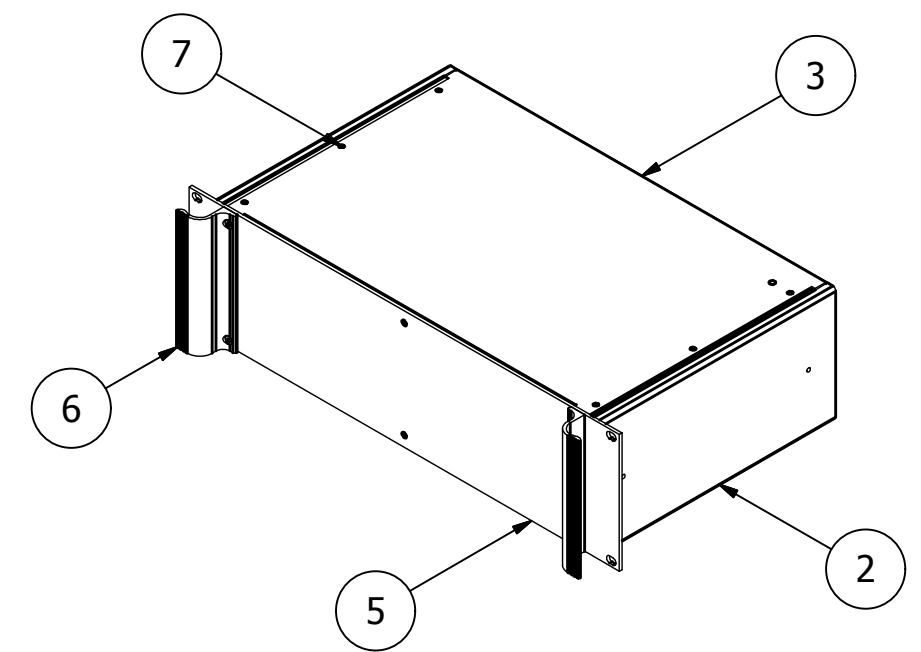
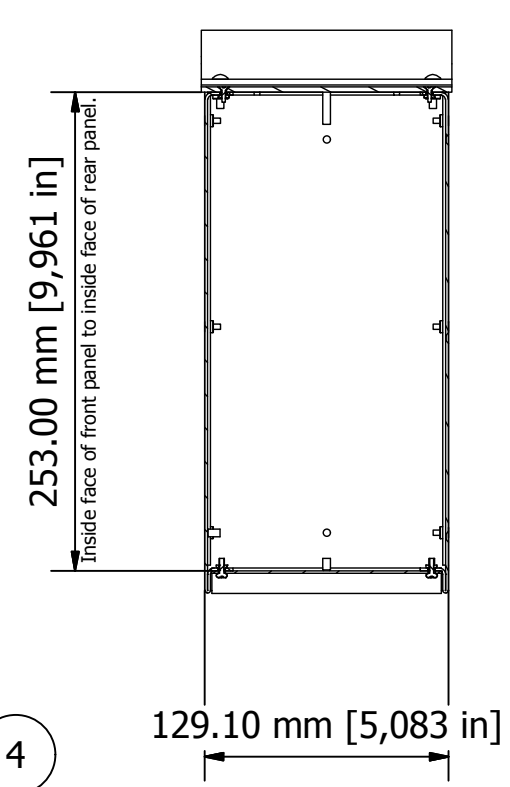

NOTES.
 Case metalwork is made from 1.5 mm aluminium and painted RAL 7035 fine texture light grey.
 Front panel is made from 3 mm aluminium with a clear etch & anodise finish.
 Handles made from an aluminium extrusion & painted RAL 7035 fine texture light grey.
 All parts are fitted with M4 studs for earth use.

PARTS LIST			
ITEM	QTY	PART NUMBER	DESCRIPTION
1	1	M6201035	Rear Panel
2	2	M6202335	Side Panels
3	1	M6203025	Top Panel
4	1	M6203035	Base Panel
5	1	M6219030	Front Panel
6	2	M6200305	Handles
7	14	M3x8 CSK Screw	Assembly Screws
8	4	M4x16 Screw	Front Panel Screws
9	6	M3x8 Pan Screw	Rear Panel Screws

FIRST ANGLE PROJECTION

Designed by L Clark	Description Combimet 2U x 19" x 265 mm Unvented	Date 29/02/2012	Scale 1:4
METCASE ENCLOSURES 15 Brunel Way, Segensworth East, Fareham, Hampshire, UK. PO15 5TX Tel: +44 (0)1489 583858 Email: metcase@okw.co.uk		METcase™ www.metcase.com Part Number M6219335	
		Issue 1	Sheet 1 / 1

© OKW Enclosures Ltd (Date as shown). This drawing contains proprietary information of OKW Enclosures Ltd and is tendered subject to the following conditions. The information be retained in confidence, not be reproduced or copied, and not be used or incorporated in any product, unless permission is obtained in writing from OKW Enclosures Ltd.