

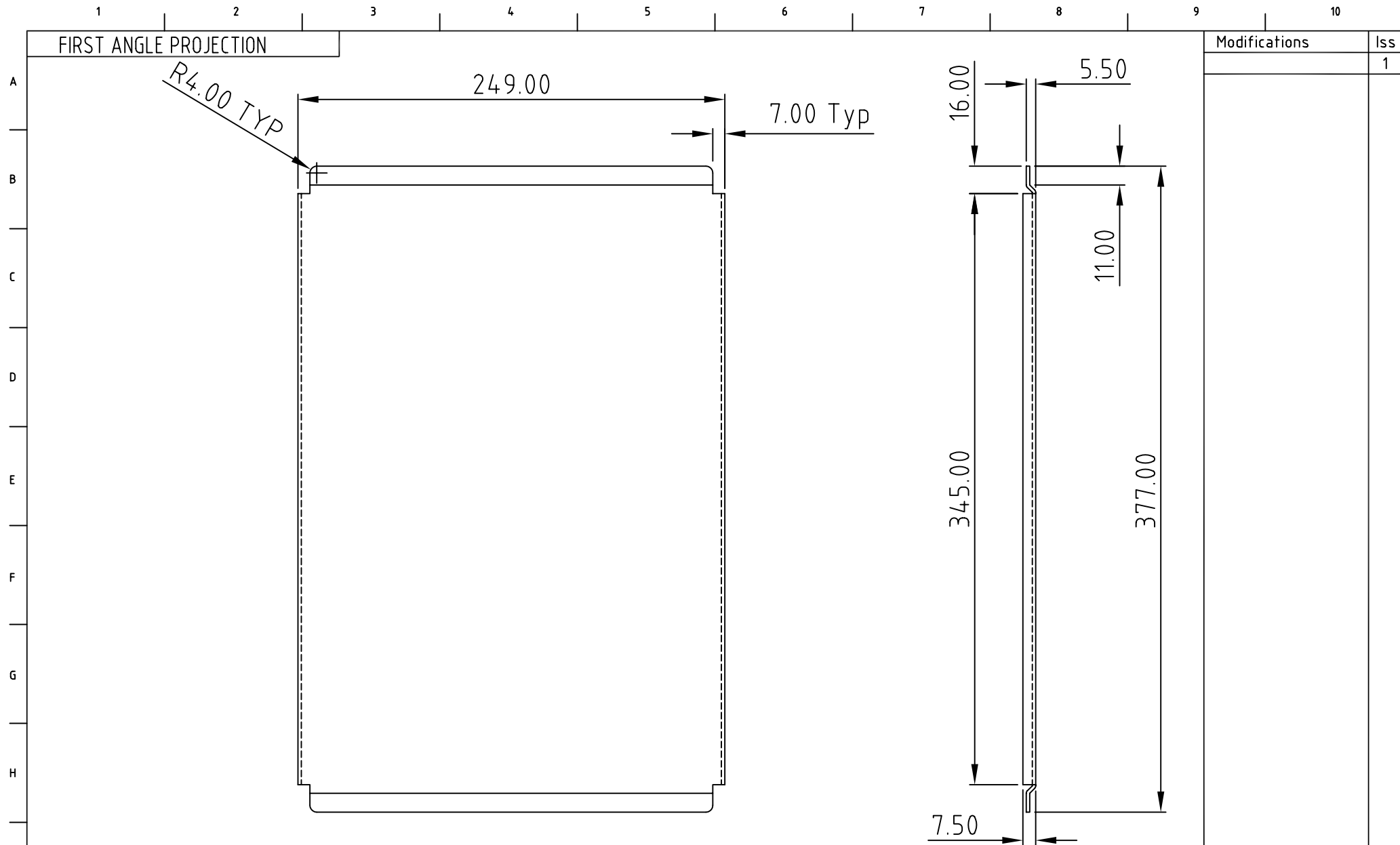

FIRST ANGLE PROJECTION



Modifications	Iss
	1

Note:
 Subject to technical modifications without prior notice.
 Typographical and other errors do not justify any claim for damages.
 All dimensions should be verified using the actual case.

Tolerances unless otherwise stated: General tolerances ±0.20 Resultant tolerances between hole centers ±0.15 Tolerances on hole diameters ±0.05 Angles ± 0.5° Surface finish 32/	Required Finish: No finish	Scale: 1:2	ALL DIMENSIONS IN MILLIMETRES			DO NOT SCALE
	 www.metcase.com METCASE ENCLOSURES Unit 3, Mitchell Close Segensworth East, Fareham, Hampshire, PO15 5SE, UK.	Drawn by: Ian Cox	Checked By:	Drawing Number: M5900202	Date drawn: August '05	Material Spec. 1.5mm aluminium
		Part Name: Chassis Plate 267.5mm			Part Number: M5900202	
					Sheet 1 of 1	
<small>©OKW ENCLOSURES LTD (DATE AS SHOWN). THIS DRAWING CONTAINS PROPRIETARY INFORMATION OF OKW ENCLOSURES LTD AND IS TENDERED SUBJECT TO THE FOLLOWING CONDITIONS: THE INFORMATION BE RETAINED IN CONFIDENCE, NOT BE REPRODUCED OR COPIED, AND NOT BE USED OR INCORPORATED IN ANY PRODUCT, UNLESS PERMISSION IS OBTAINED IN WRITING FROM OKW ENCLOSURES LTD.</small>						
						A3