

FIRST ANGLE PROJECTION

Note: Subject to technical modifications without prior notice.  
 Typographical and other errors do not justify any claim for damages.  
 All dimensions should be verified using the actual case.

Modifications

Iss

1

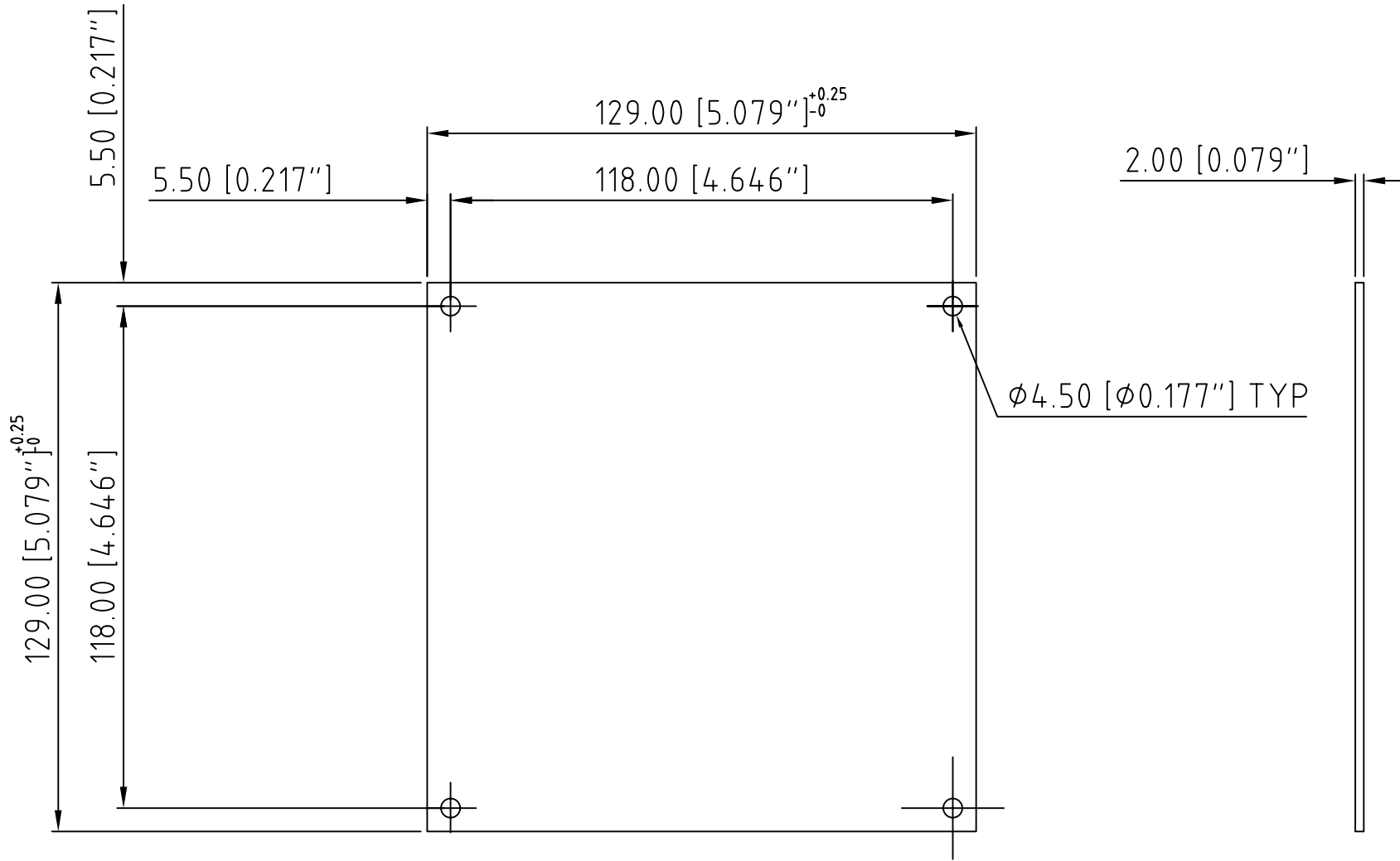

Tolerances unless otherwise stated: General tolerances $\pm 0.20$ Resultant tolerances between hole centers $\pm 0.15$ Tolerances on hole diameters $\pm 0.05$ Angles $\pm 0.5^\circ$ Surface finish $\sqrt{3}$	Required Finish: Etch & Clear Anodise	Scale: 1:1 Drawn by: Ian Cox	ALL DIMENSIONS IN MILLIMETRES			DO NOT SCALE
			Drawing Number M5215601	Date drawn: August '05	Material Spec. 2mm aluminium	
	<b>METcase</b> METCASE ENCLOSURES Unit 3, Mitchell Close Segensworth East, Fareham, Hampshire, PO15 5SE, UK.		Part Name Front Panel FF - "S"		Part Number M5215601	Sheet 1 of 1
	www.metcase.com		©OKW ENCLOSURES LTD (DATE AS SHOWN). THIS DRAWING CONTAINS PROPRIETARY INFORMATION OF OKW ENCLOSURES LTD AND IS TENDERED SUBJECT TO THE FOLLOWING CONDITIONS: THE INFORMATION BE RETAINED IN CONFIDENCE, NOT BE REPRODUCED OR COPIED, AND NOT BE USED OR INCORPORATED IN ANY PRODUCT, UNLESS PERMISSION IS OBTAINED IN WRITING FROM OKW ENCLOSURES LTD.			