

Oberteil ohne Vertiefung
top part without recessed area

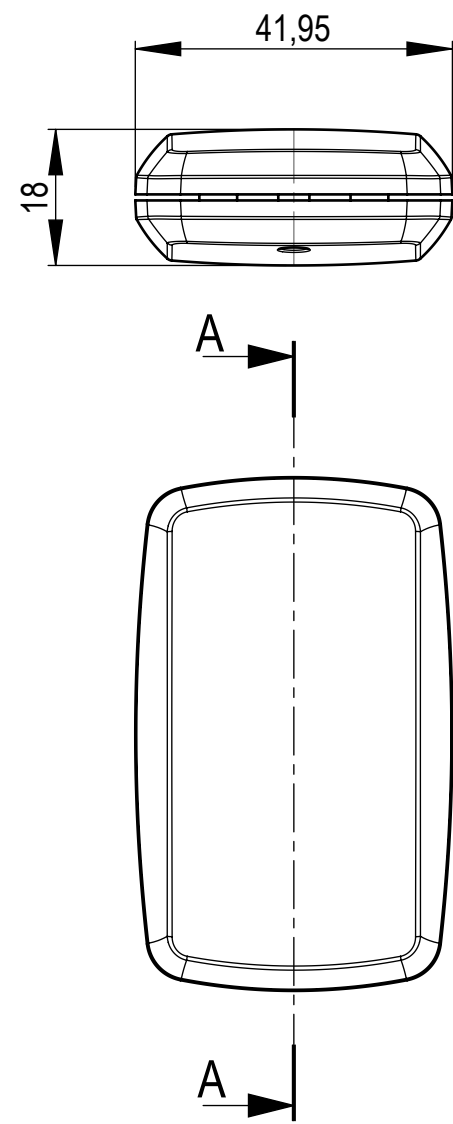

Unter- und Oberteil (nur in Kombination mit Zwischenring)
bottom and top part (only in combination with intermediate ring)

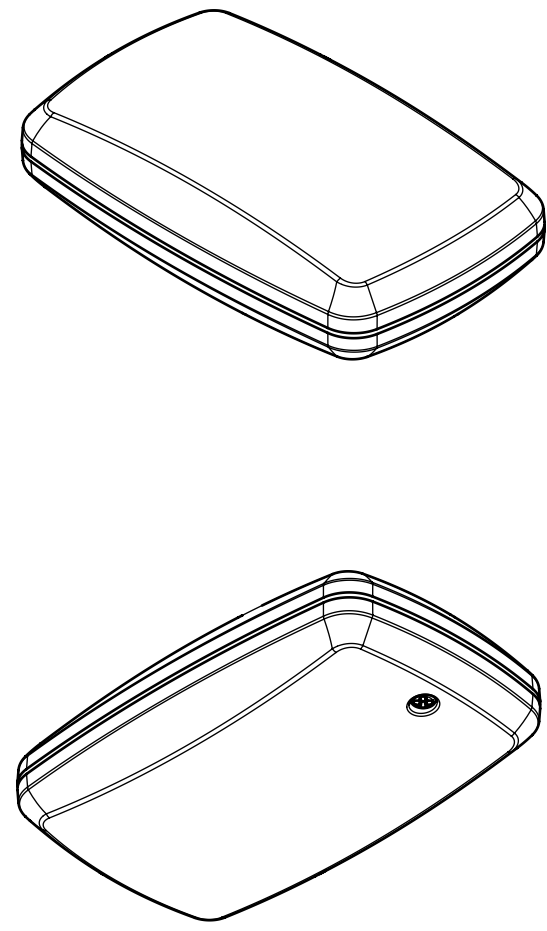
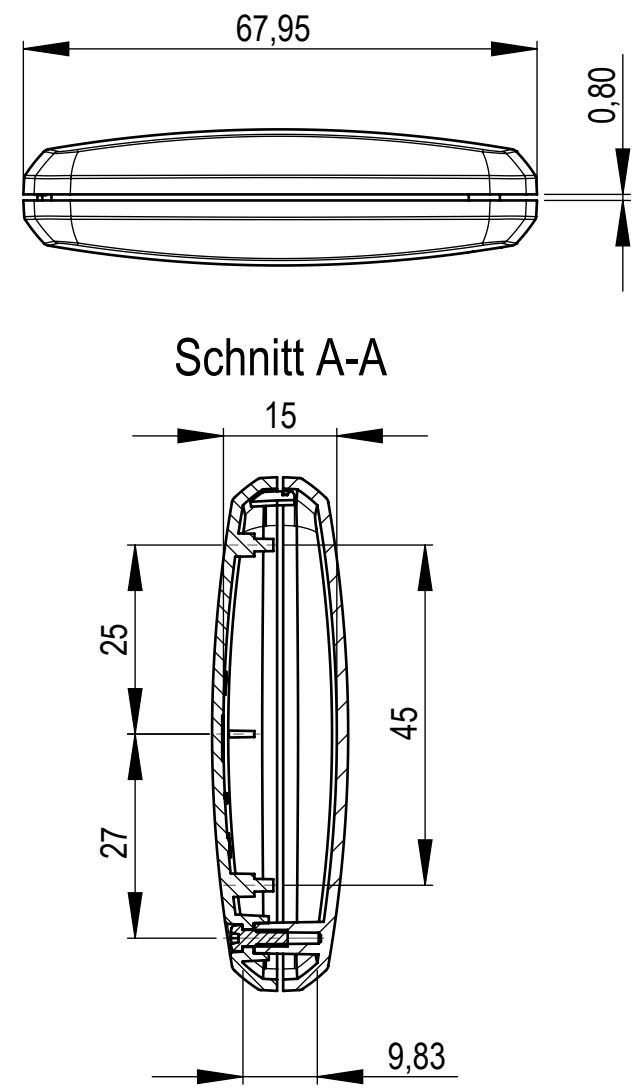

Oberteil mit Vertiefung
top part with recessed area

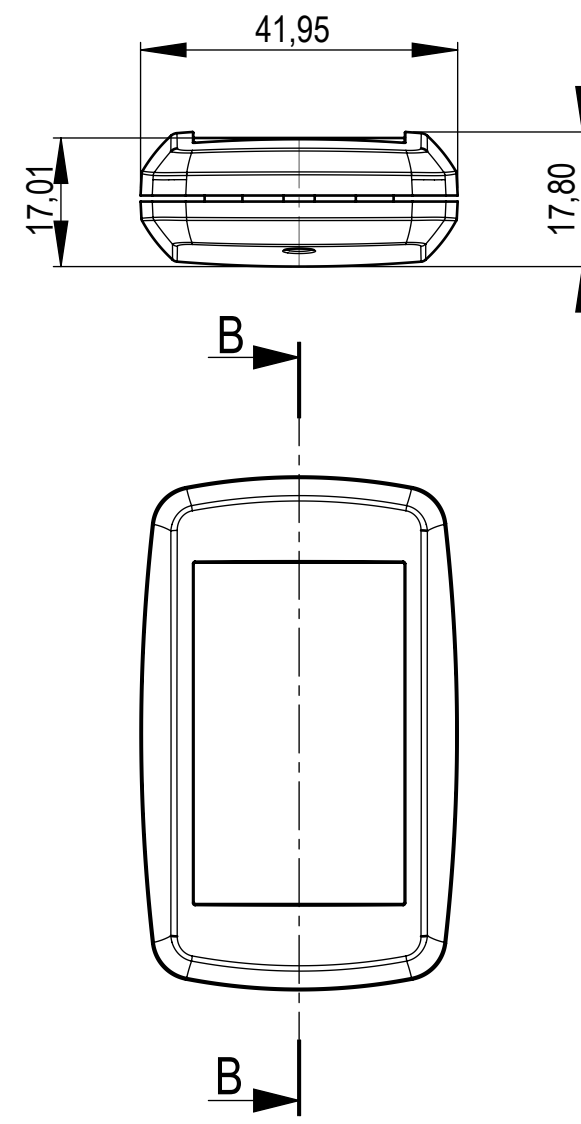

Unter- und Oberteil (nur in Kombination mit Zwischenring)
bottom and top part (only in combination with intermediate ring)

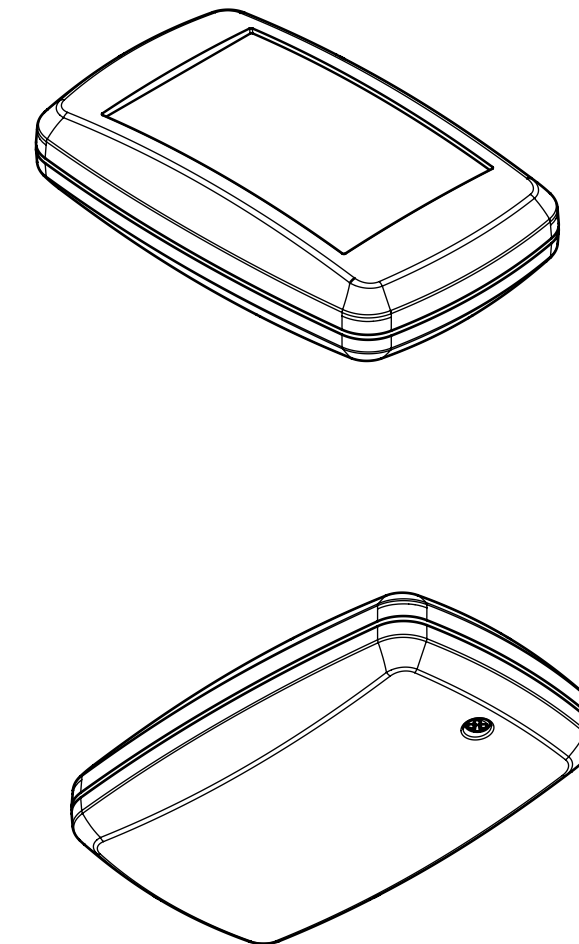
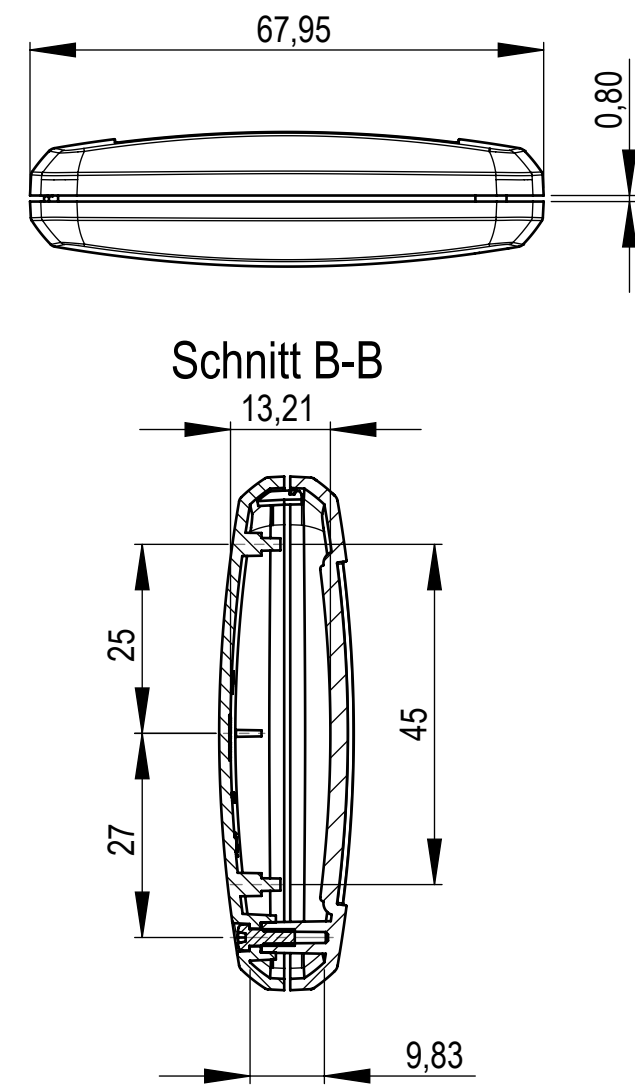

Unterteil
bottom part

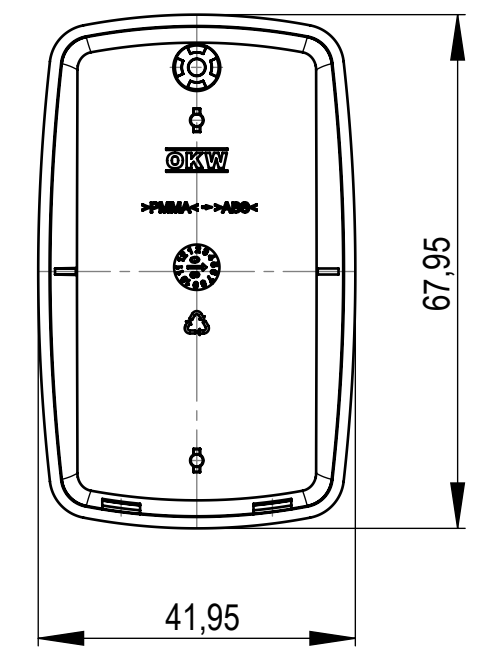

Oberteil ohne / mit Vertiefung
top part without / with recessed area

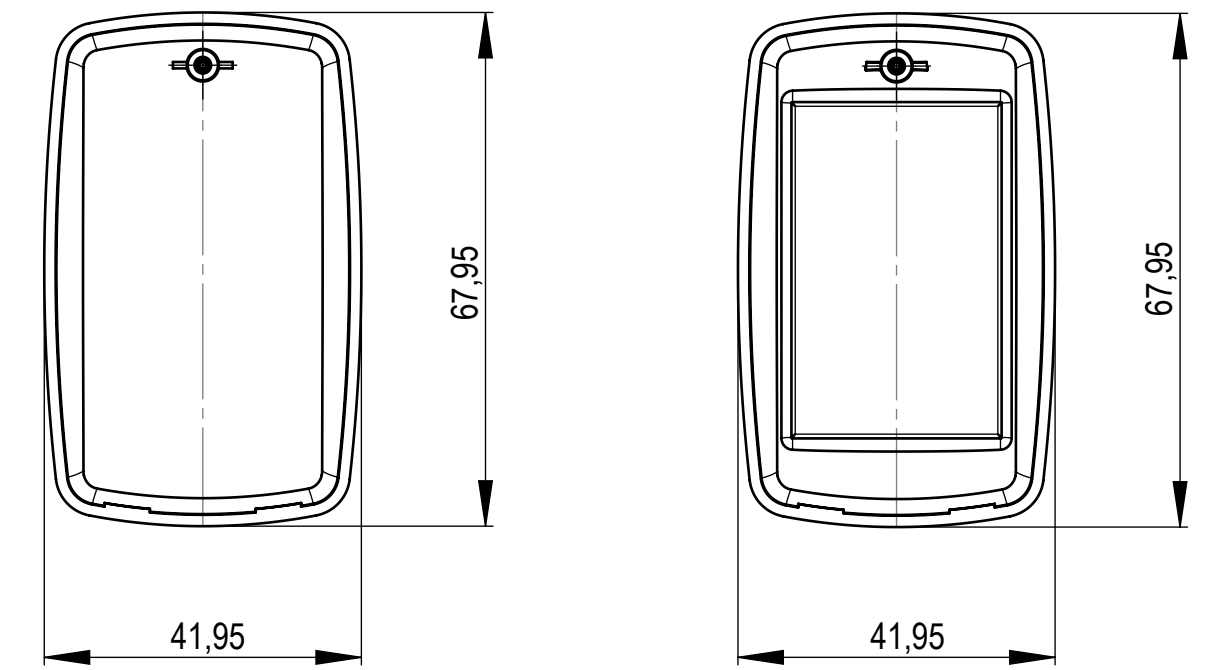

mit 1 Öse
with 1 strap loop

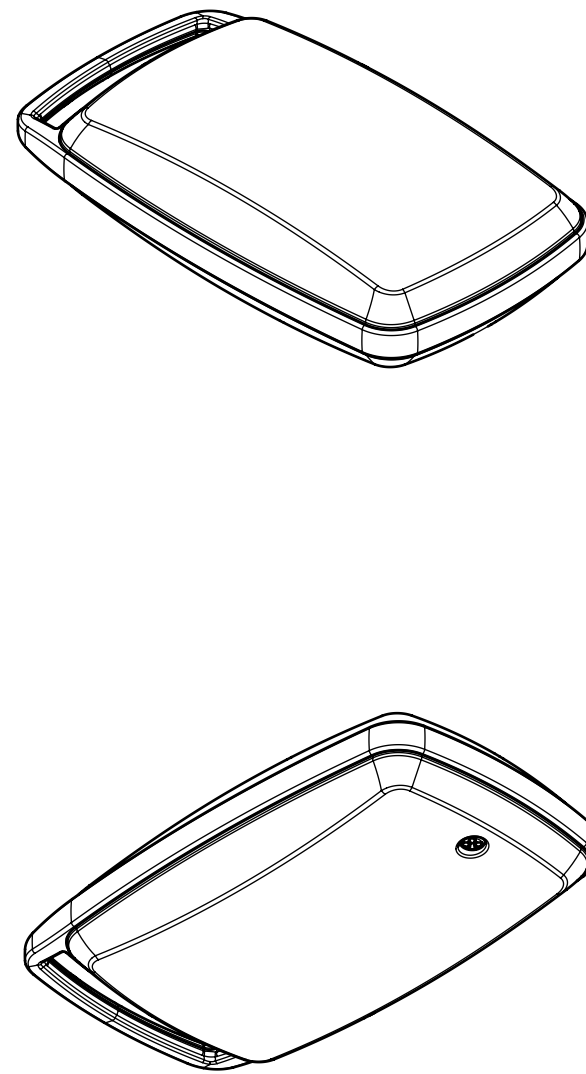
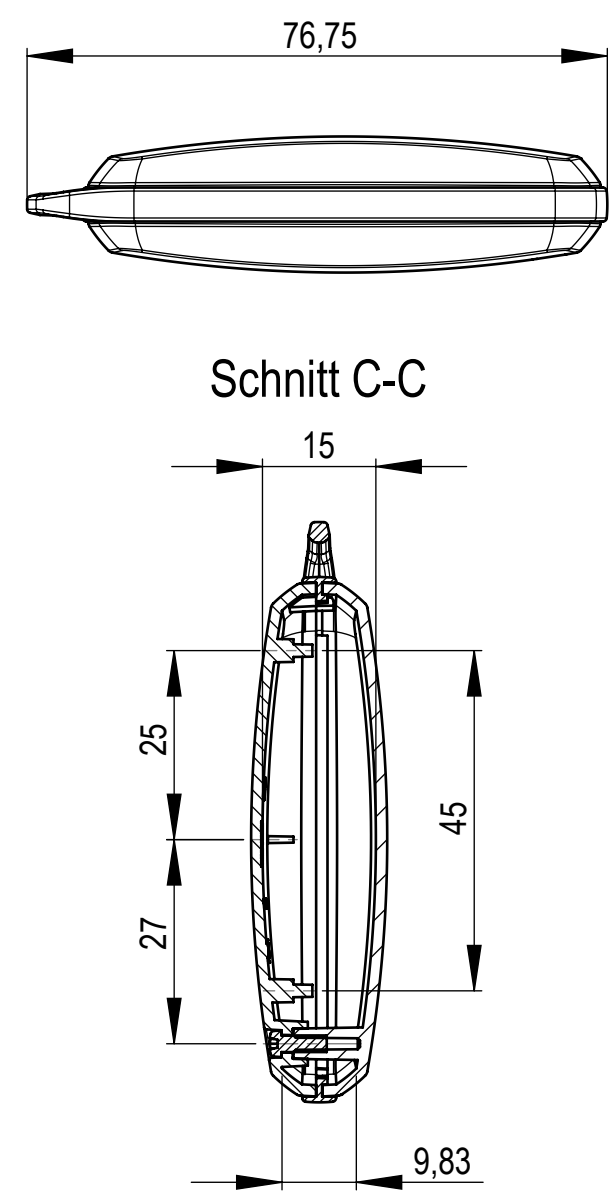
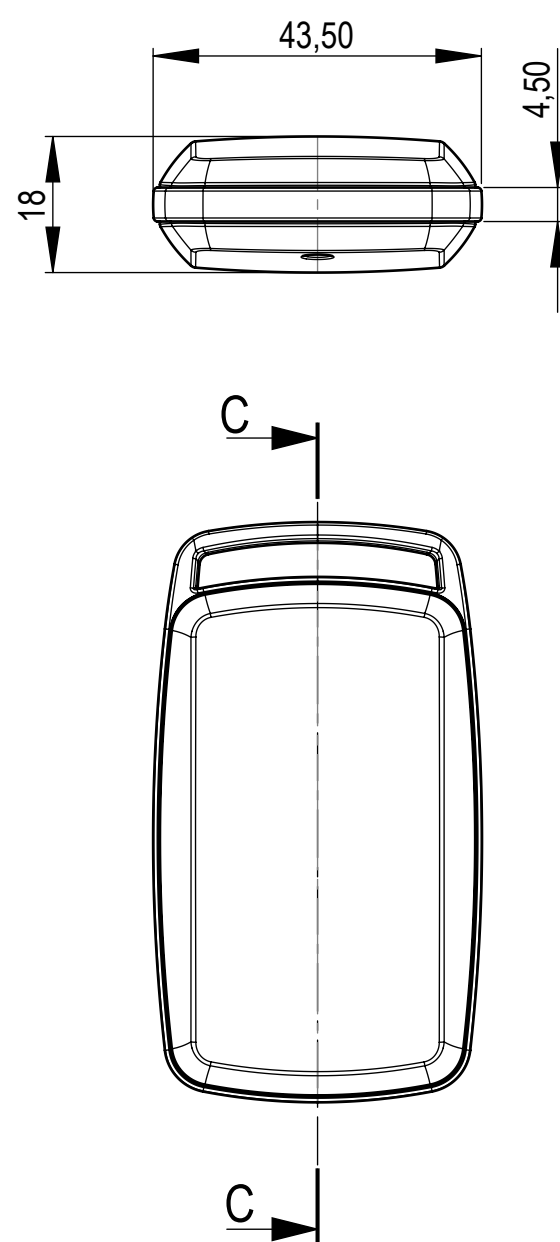

mit 1 Öse
with 1 strap loop

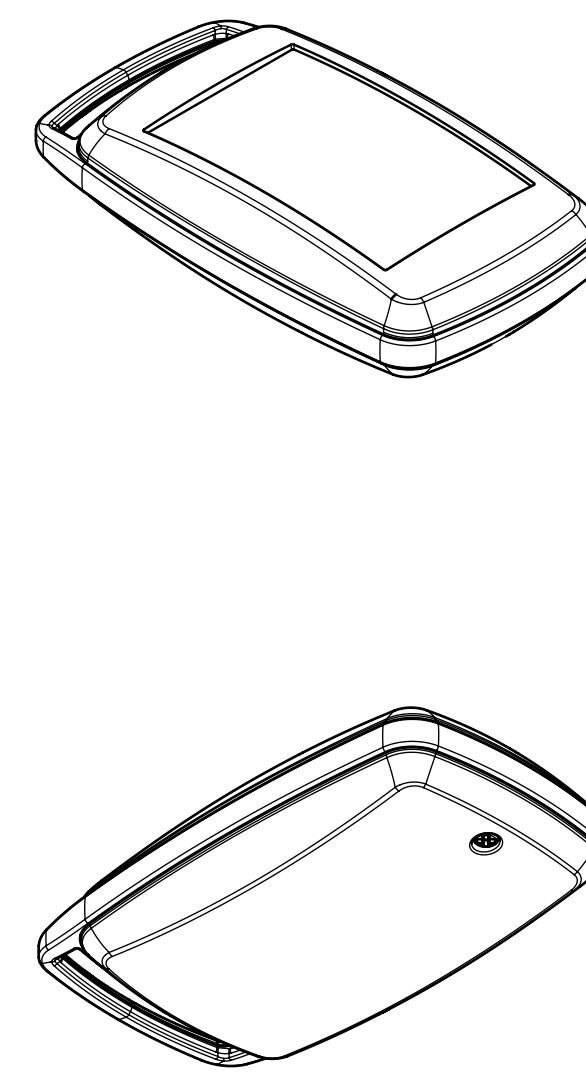
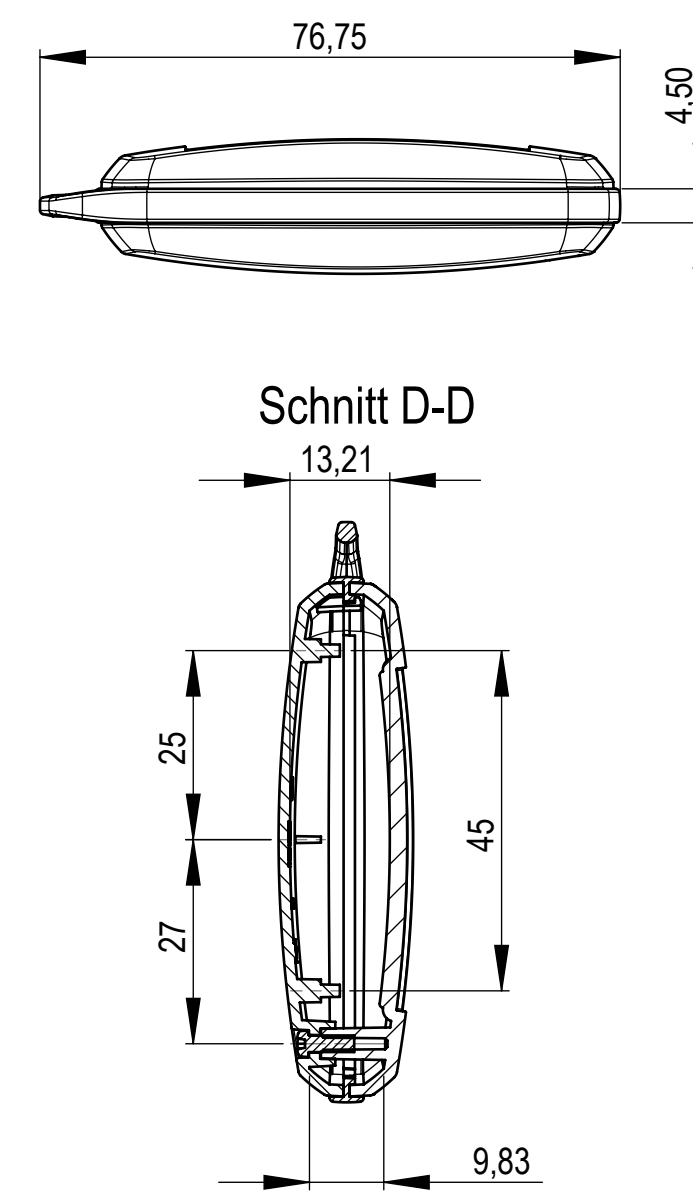
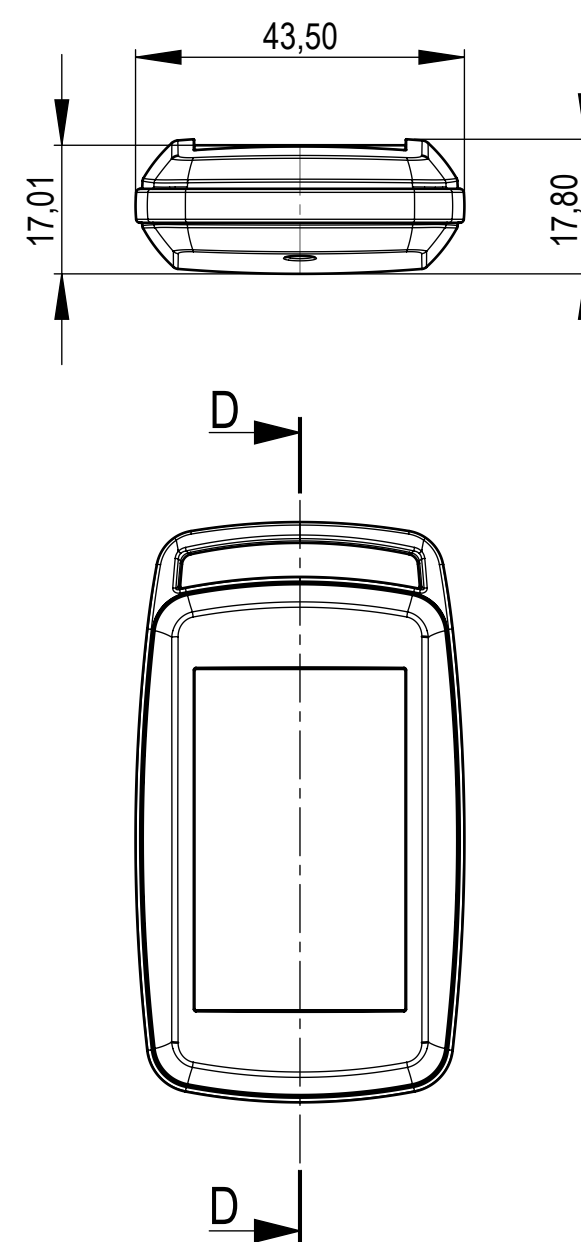

Platine UT
P C B

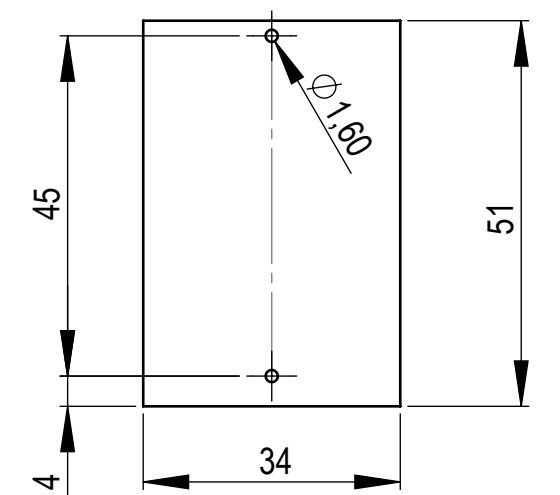

mit 2 Ösen
with 2 strap loops

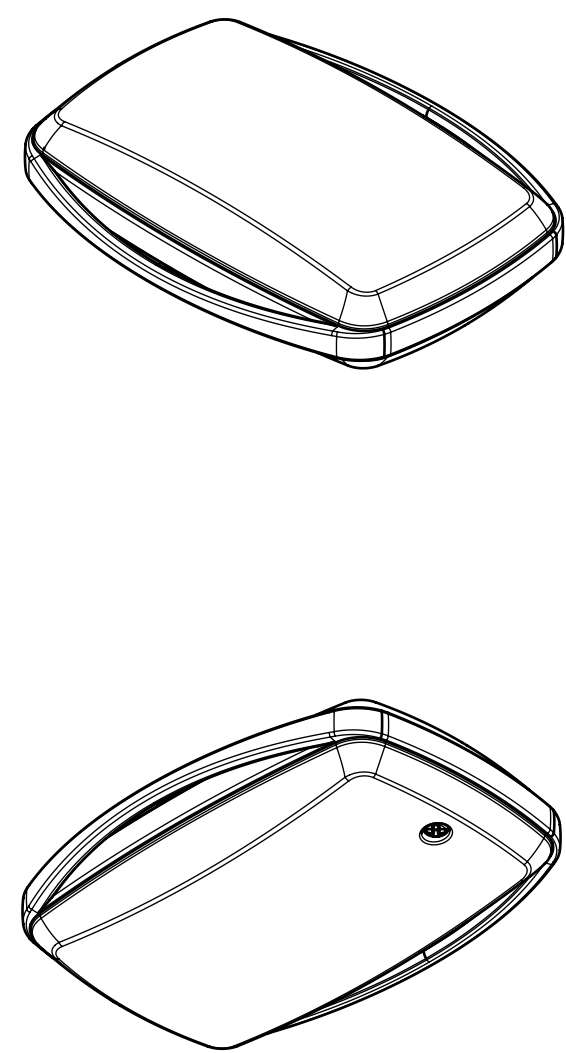
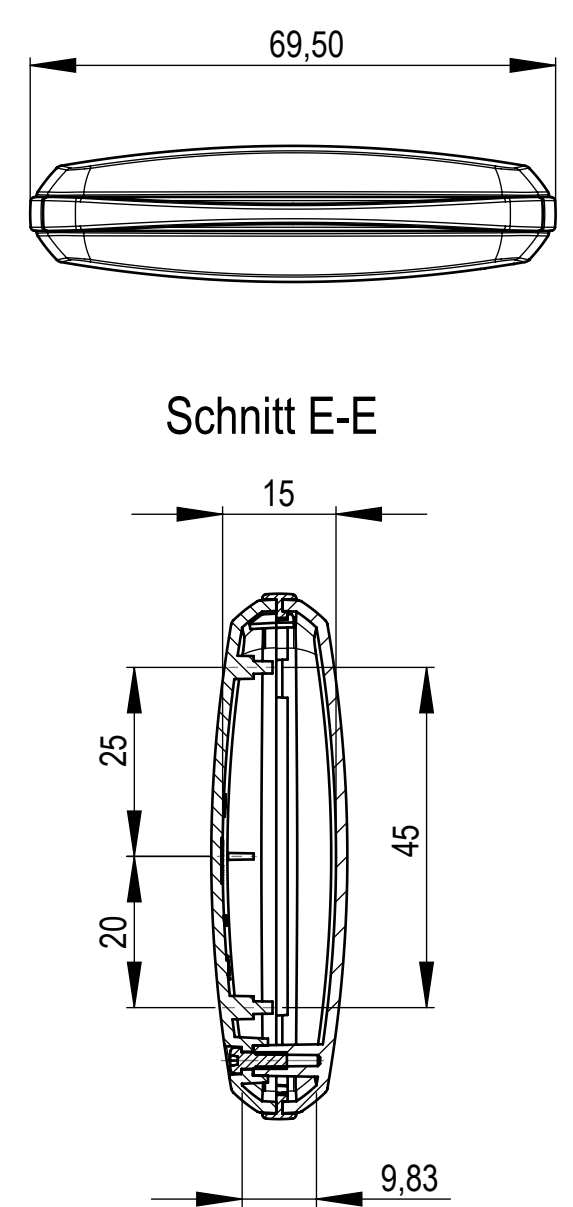
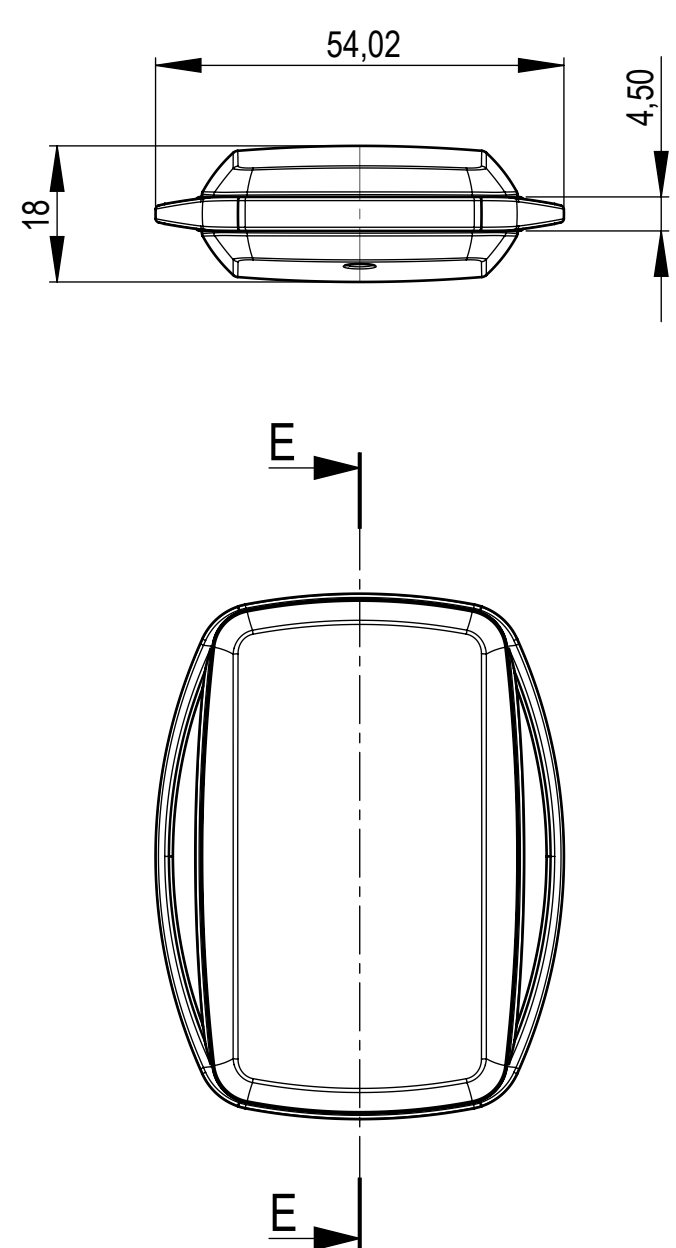

mit 2 Ösen
with 2 strap loops

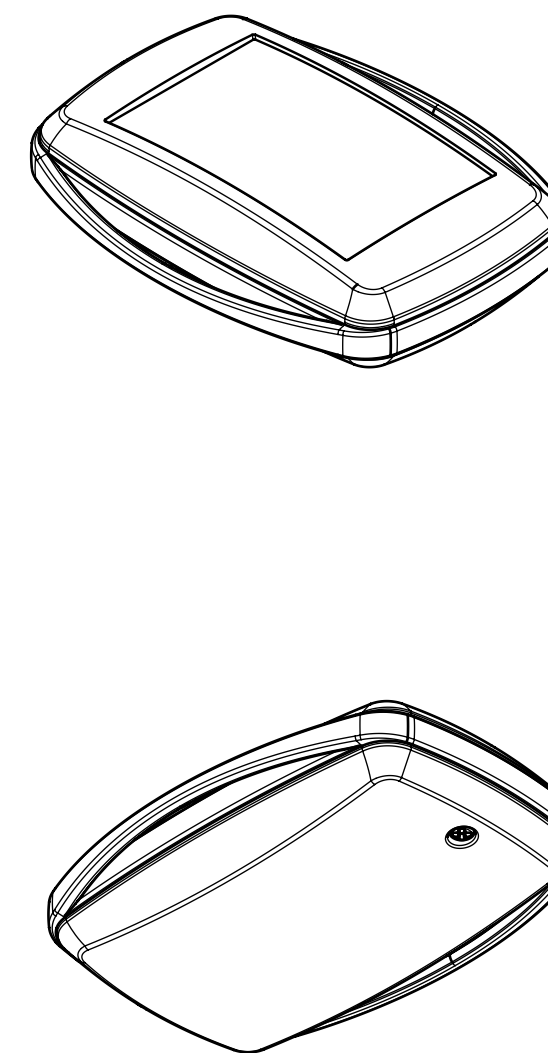
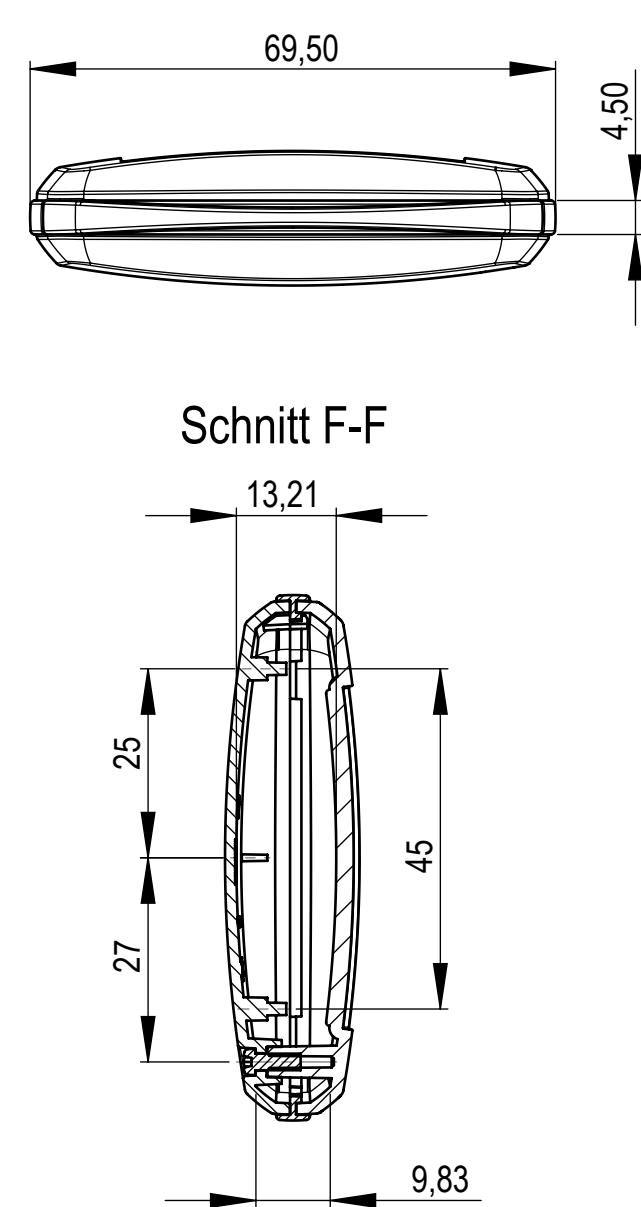
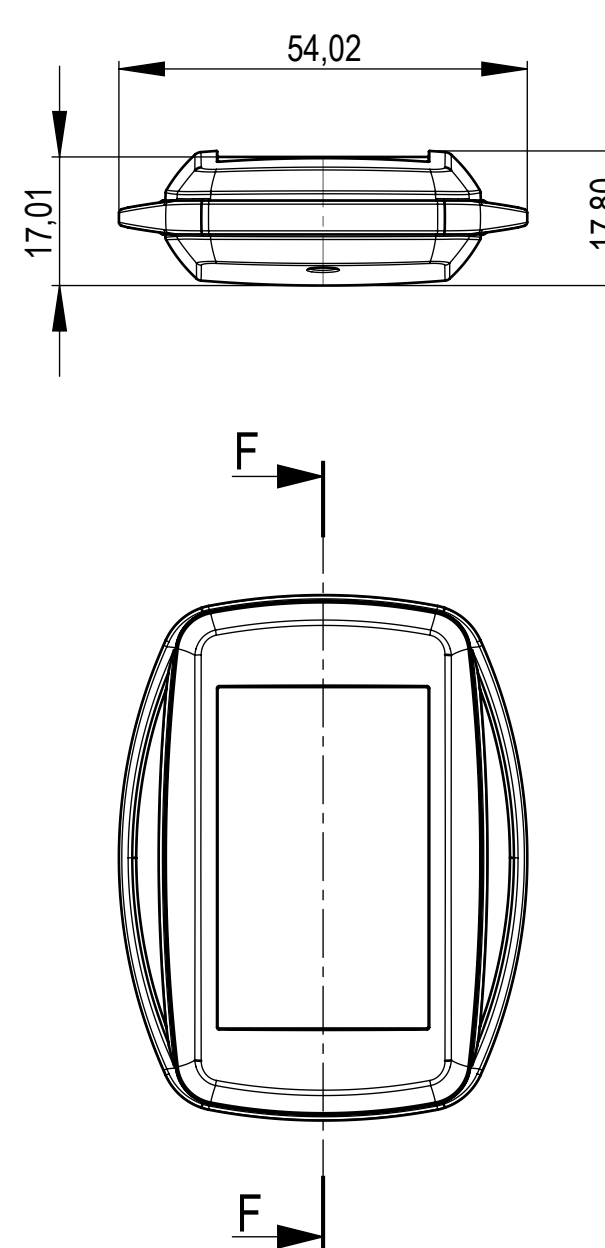

Folientastatur
membrane keyboard

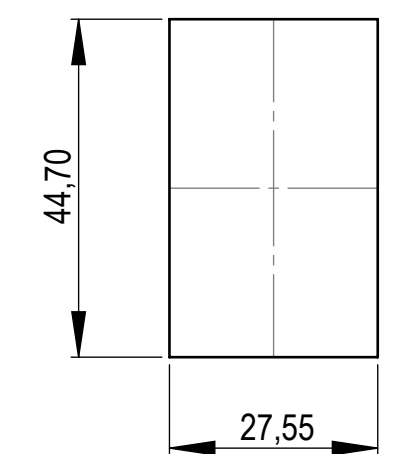

Hinweis: Zwischenring als separater Artikel B 90 04 7..
Note: intermediate ring as separate article B 90 04 7..

Informationskopie wird nicht aktualisiert Copy for Information will not be updated	Erst. am: 30.09.2009 Erst. von: Herrlich	Toleranzen: Volumen:	Status: ÄNDERUNG	DIN 6 Teil 2
	Freig. am: Freig. von: Revision: 02	Zeichnungsart: KUNDE	This document contains proprietary information of OKW Gehäuseysteme GmbH and is rendered subject to the conditions that the information be retained in confidence and not be reproduced or copied and not be used or incorporated in any product.	
Technische Änderungen vorbehalten. Irrtümer oder Druckfehler begründen keinen Anspruch auf Schadensersatz. Wichtige Einbaumaße bitte direkt mit dem aktuellen Produkt bestimmen. Subject to technical modification without prior notice. Typographical and other errors do not justify any claim for damages. All dimensions should be verified using an actual moulded part. Sous réserve de modifications techniques. Toute erreur ou faute d'impression ne justifie aucune demande d'indemnisation. Nous prions les clients de vérifier les dimensions des composants avec les boîtiers avant le montage.	OKW GEHÄUSE SYSTEME	MINITEC E M mit Ring 1 und Ring 2 B90048**	M 1:1 Für dieses Dokument behalten wir uns alle Urheberrechte vor. Es darf auch auszugsweise weder vervielfältigt noch Dritten in irgendeiner Form zugänglich gemacht werden. Dateiname: 00011816	